

Shandong University of Technology

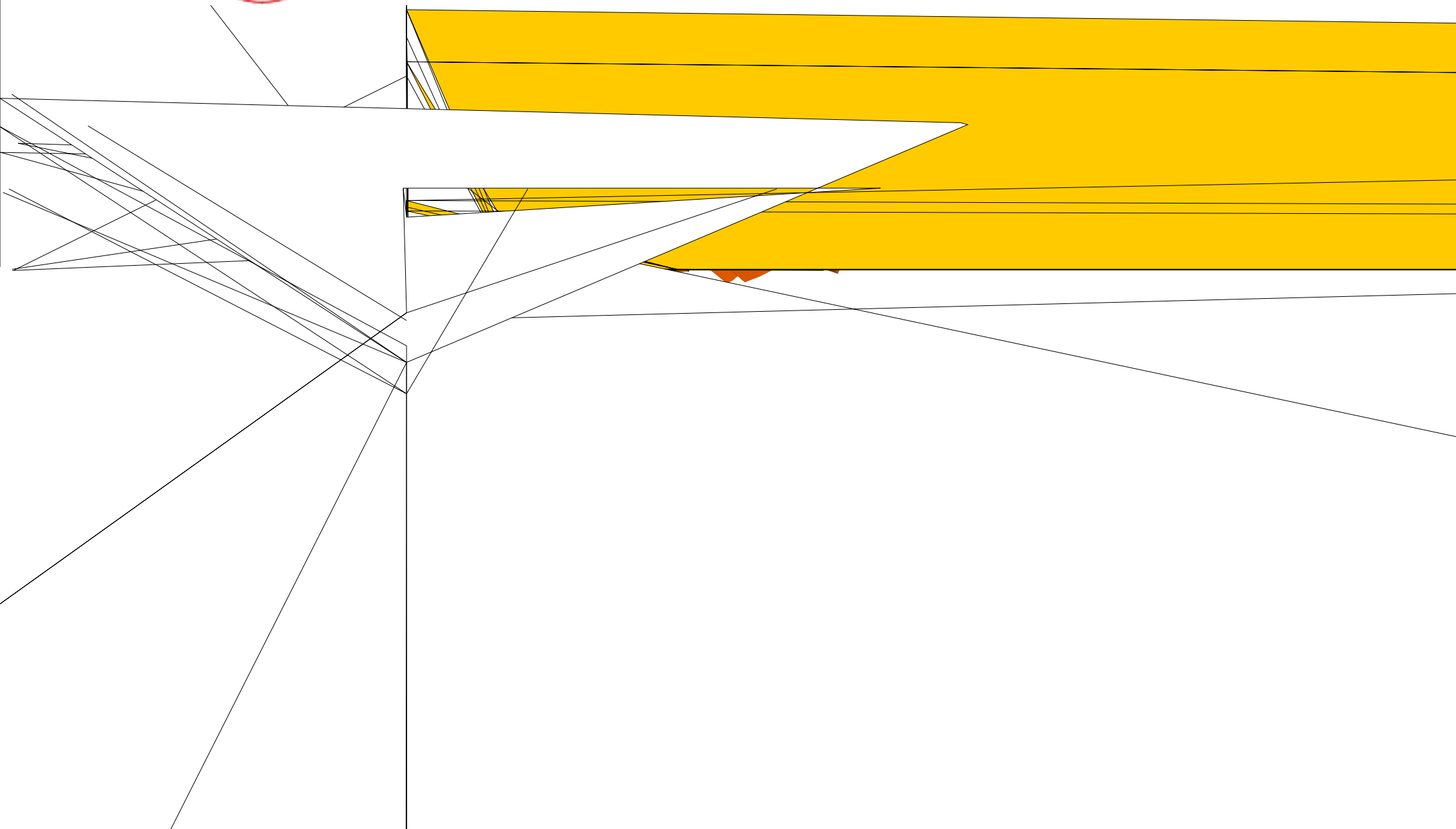





1.

:

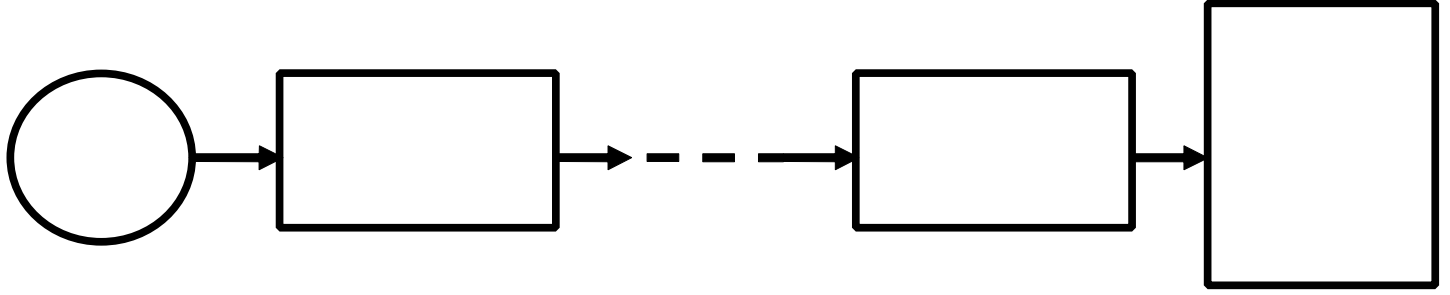

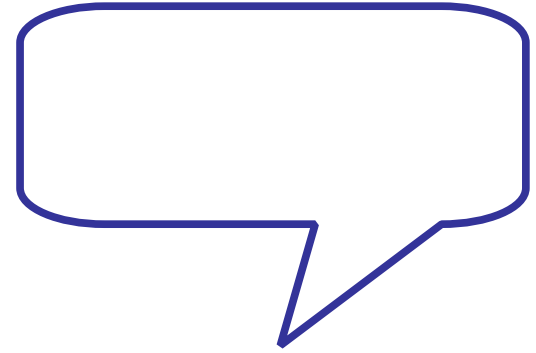
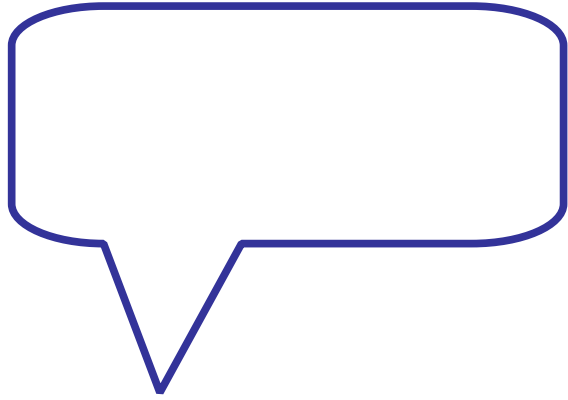

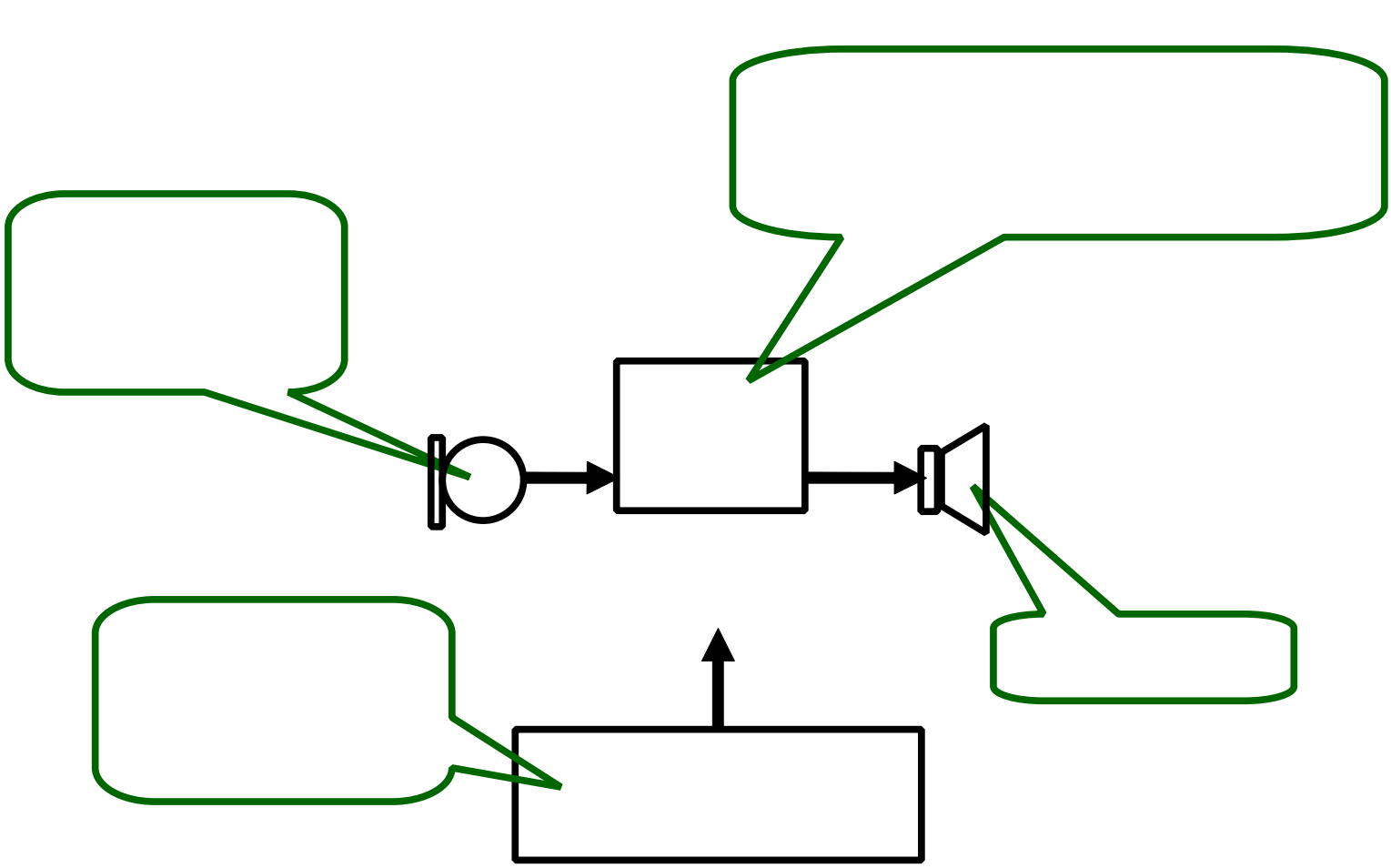

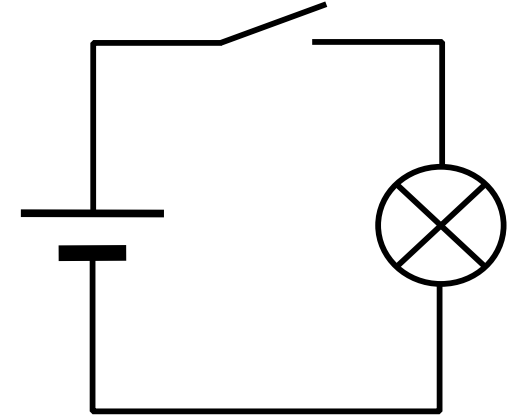
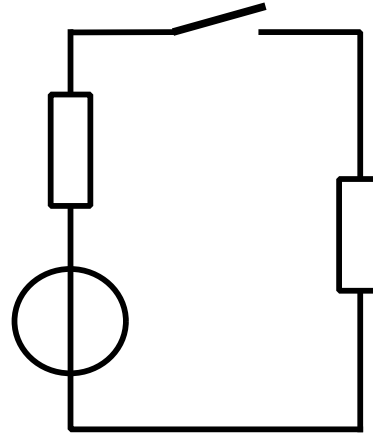
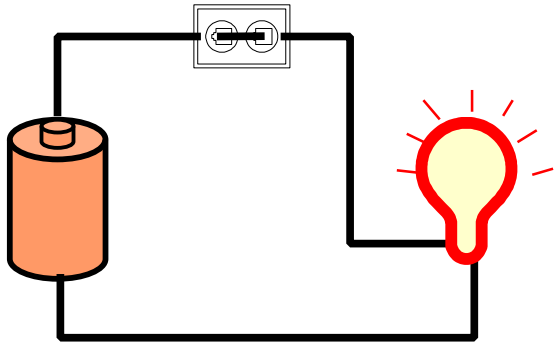

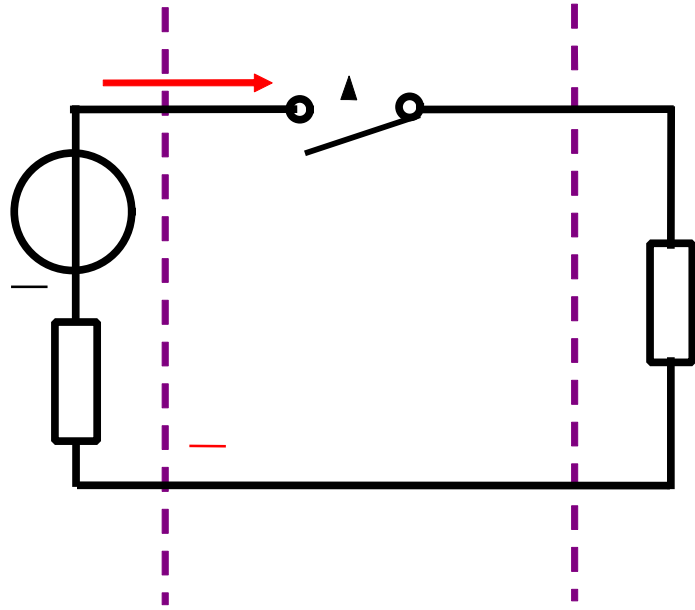





$$= \frac{\Delta}{\Delta} \frac{\Delta}{\Delta} \frac{\Delta}{\Delta}$$

$\mu$

$\mu$

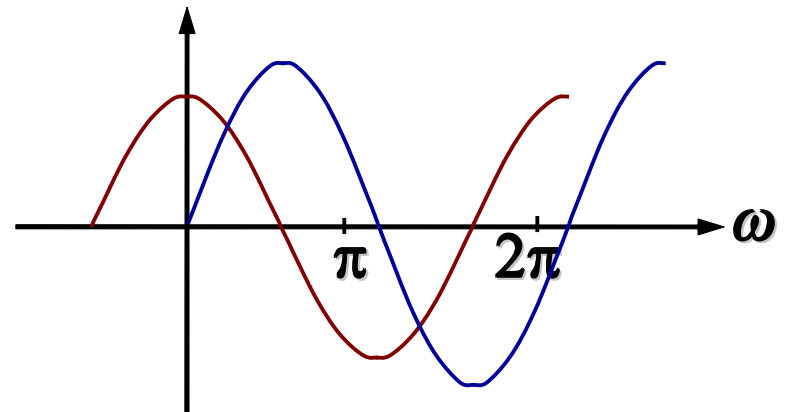
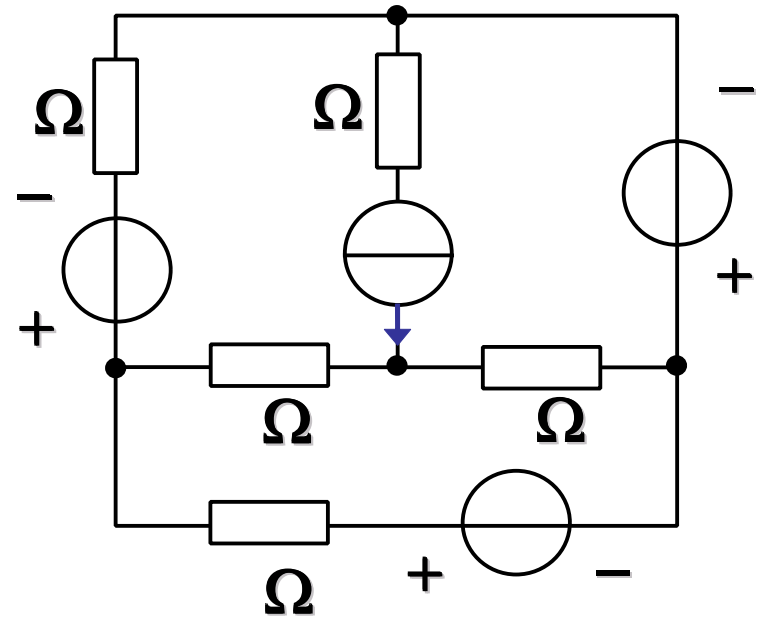
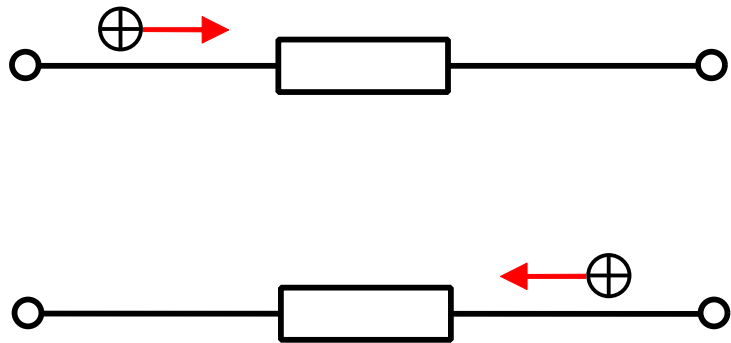

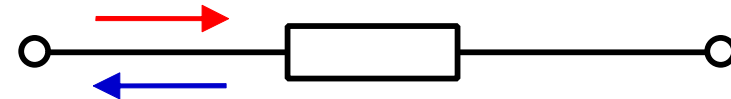
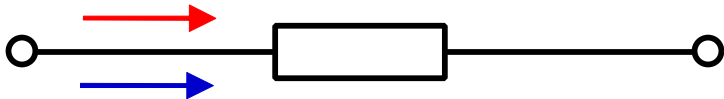
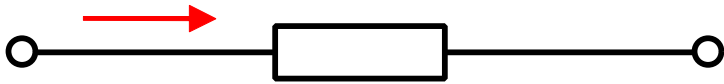



== —

$\mu$



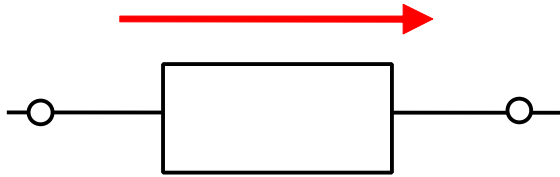



.

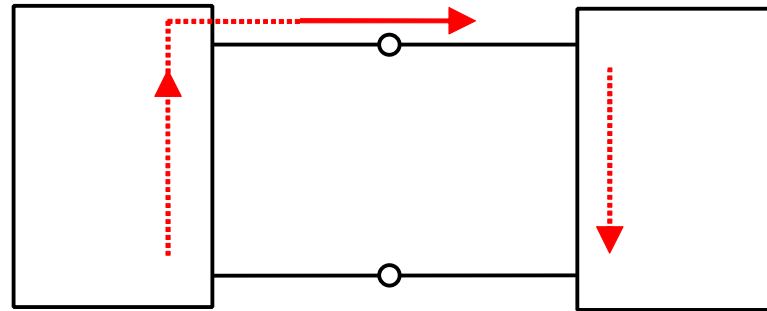
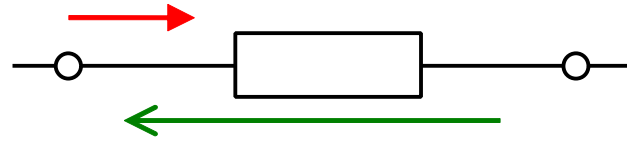
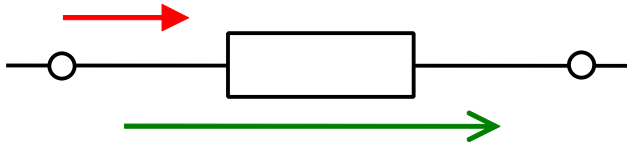







— — —  
— — —

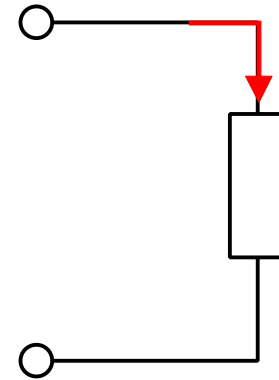
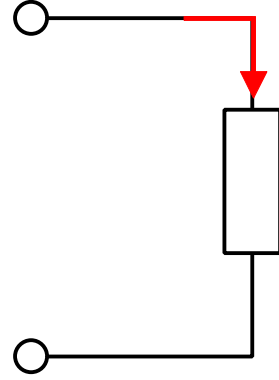



$=$   $= -$   
 $=$   $= -$   
 $=$   $= -$   
 $=$   $= -$

$=$   $= \times$   $=$   
 $=$   $= 8 \times$   $= 1$   
 $=$   $= 7 \times (-1) = -$

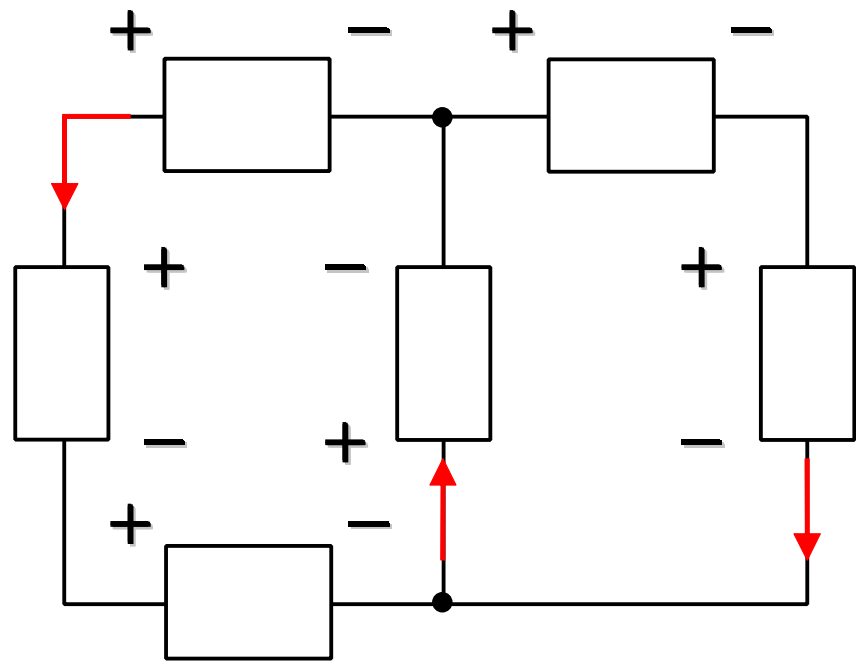

$=$   $= (-3) \times$   $= -$   
 $=$   $= (-4) \times 1 = -$   
 $=$   $= (-3) \times (-1) =$





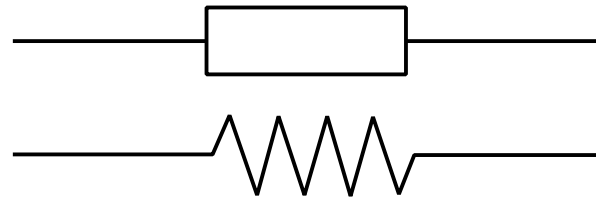
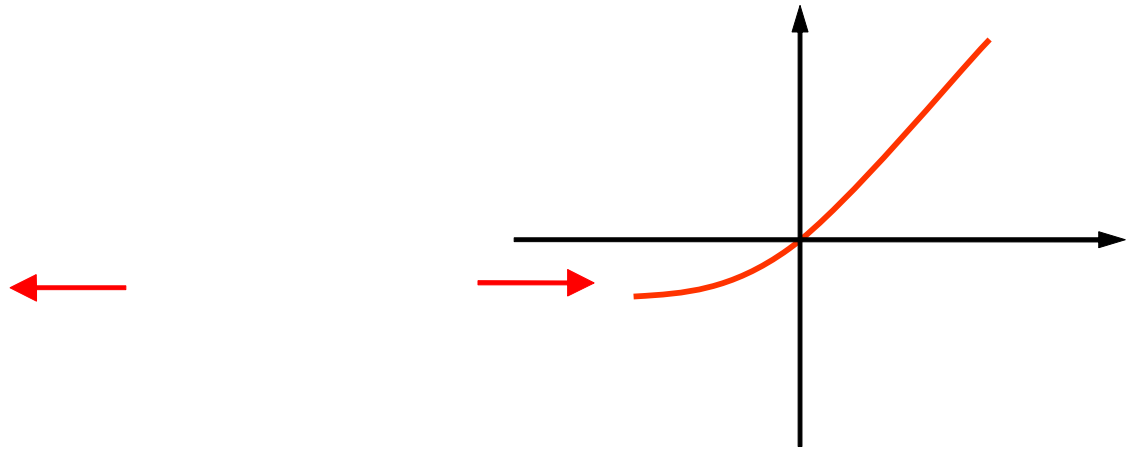

—

—

$\Omega$

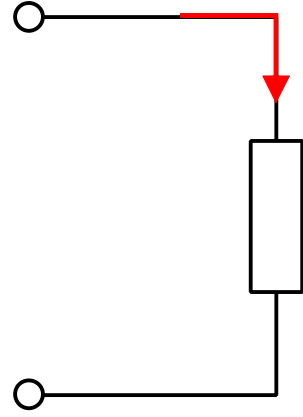
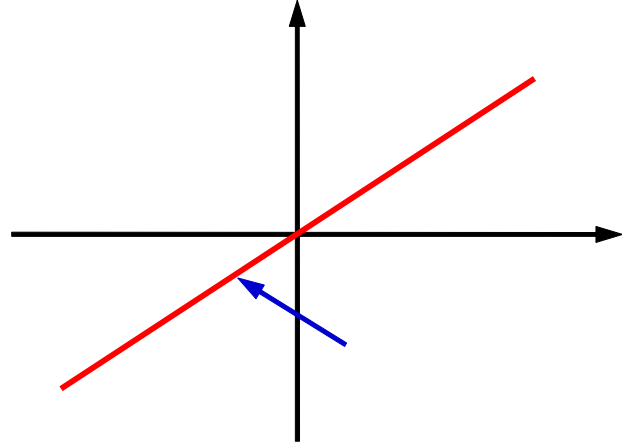



=

=

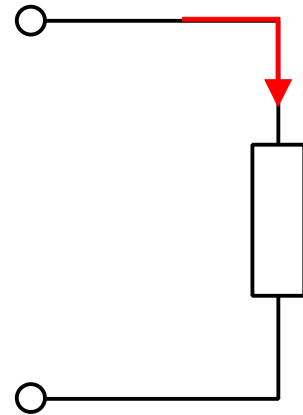

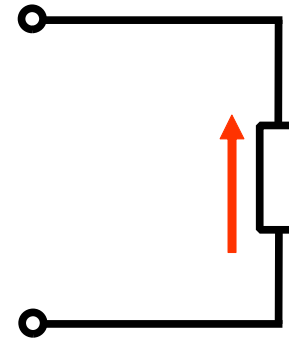
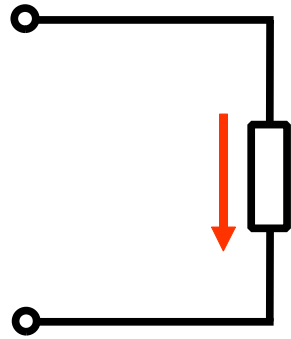

= - - = - - =

= - - - - = - - - - =

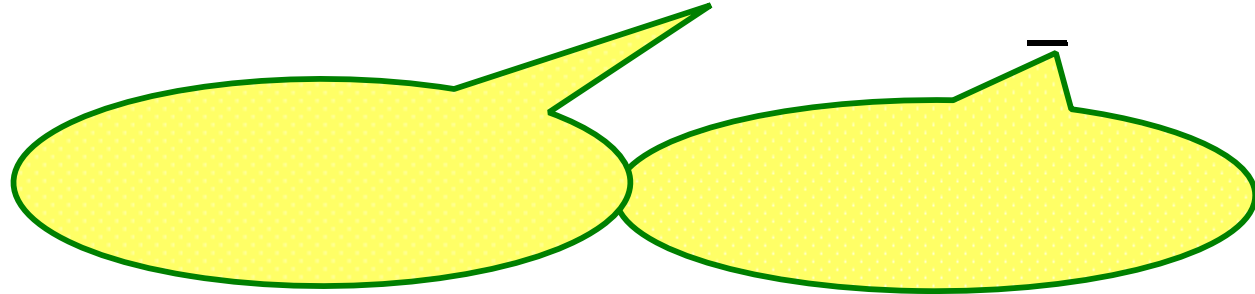



—

—

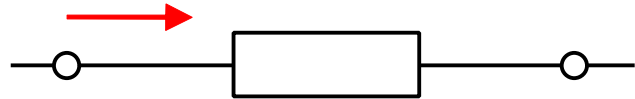
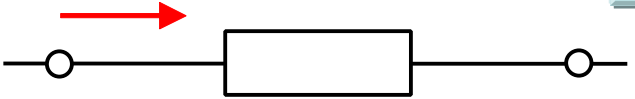

—

§

§

§

§

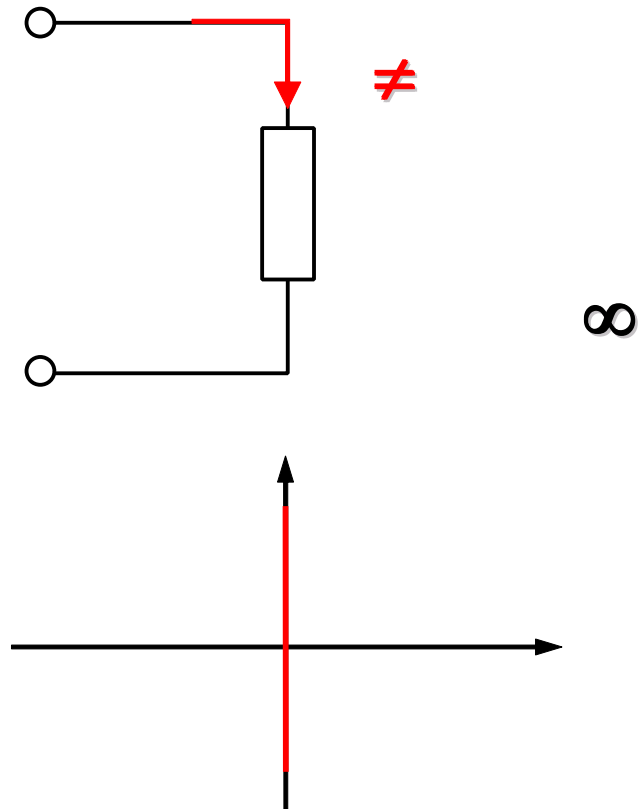
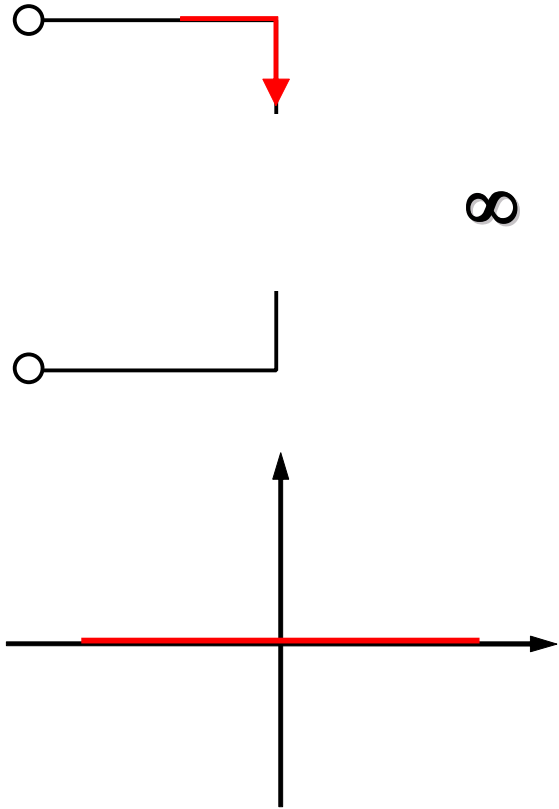

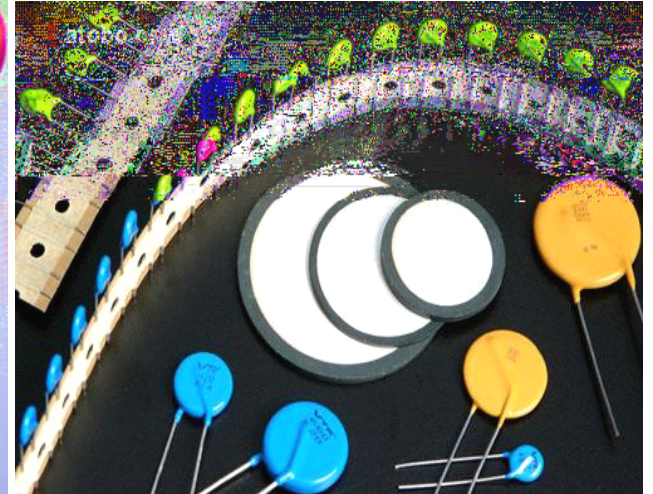
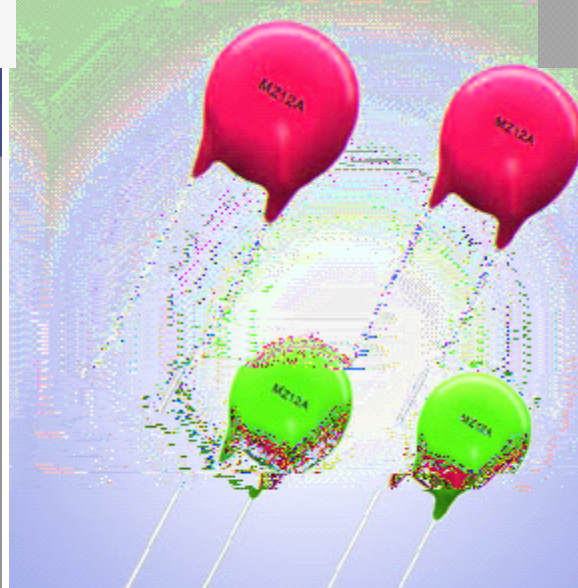
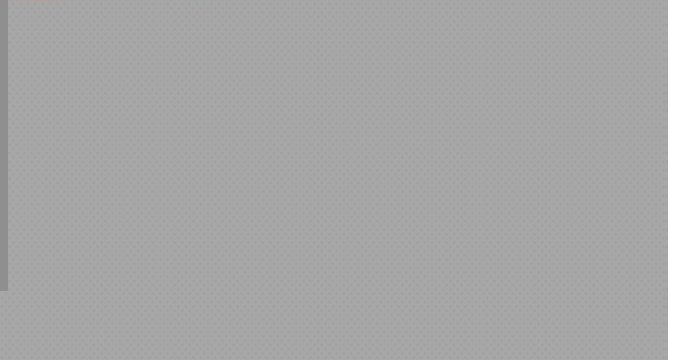
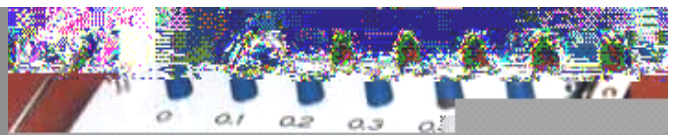
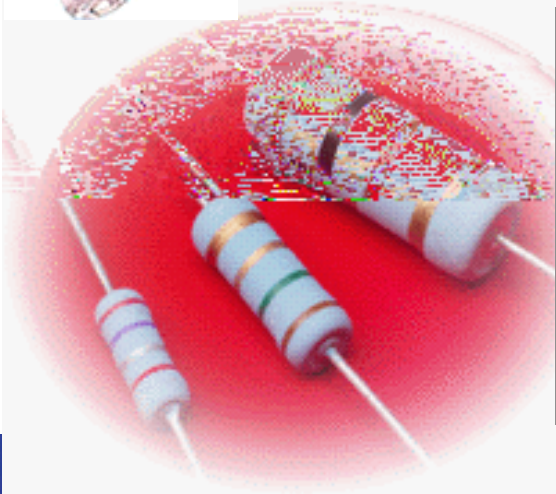

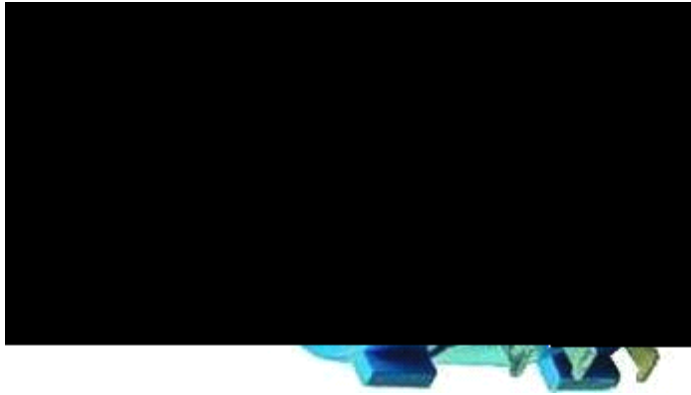
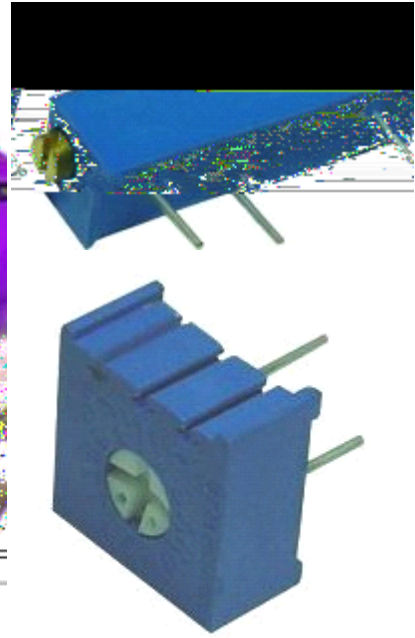
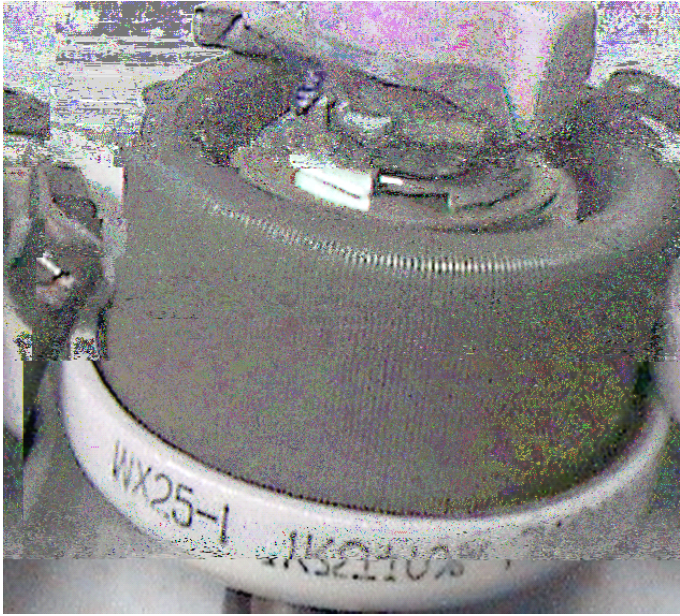

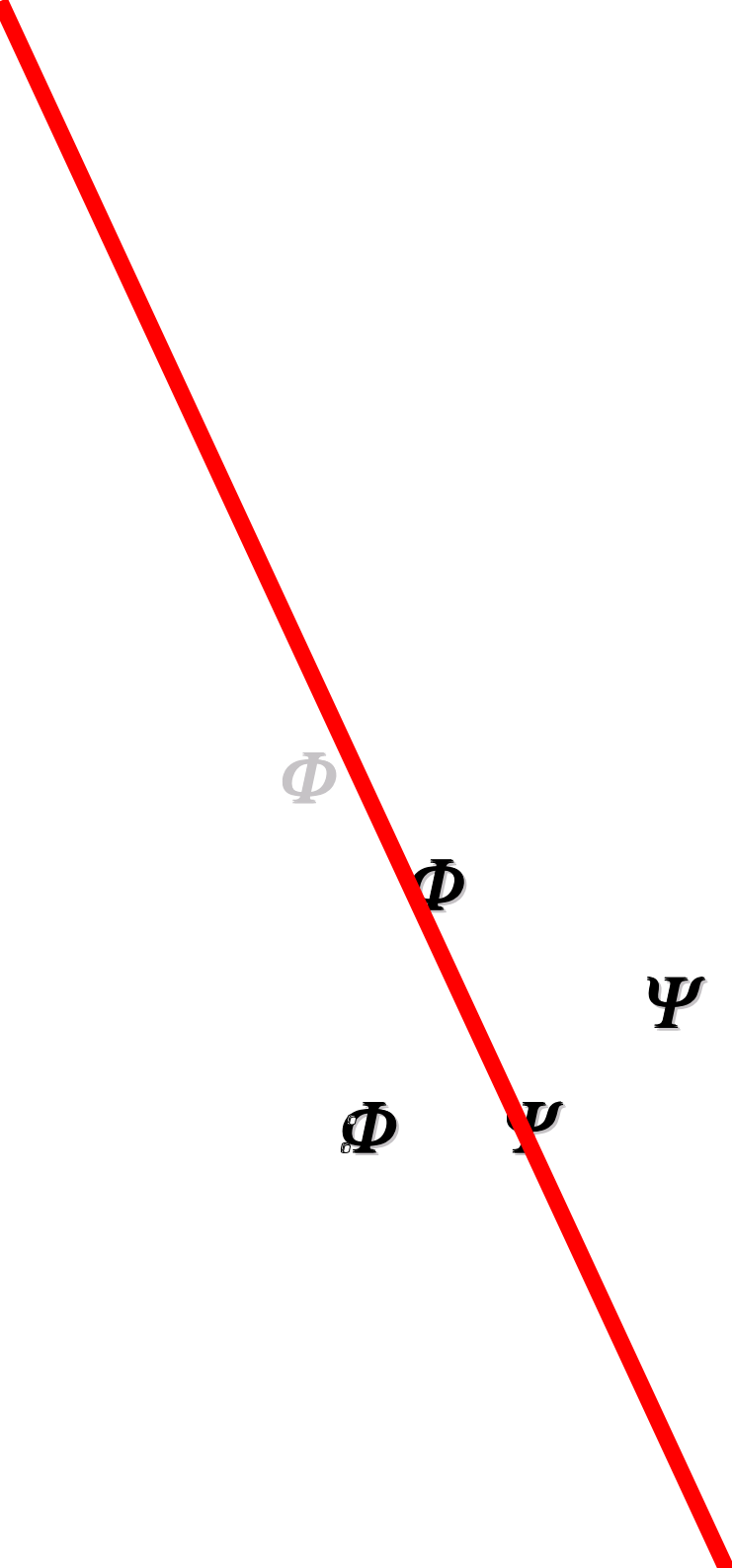

$\Phi$

$\Phi$

$\Psi$

$\Psi$

$\Phi$

$\Phi$

$\Psi$

$\mathcal{M}$

$\Phi$

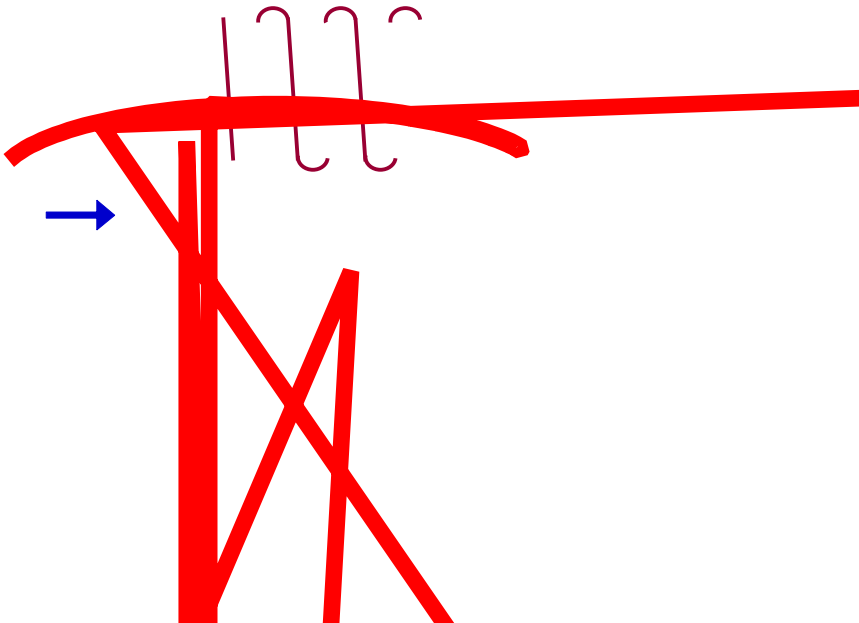



$\Psi$

$\Psi$

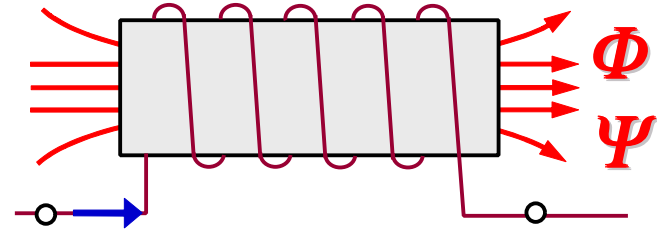

$\Psi$



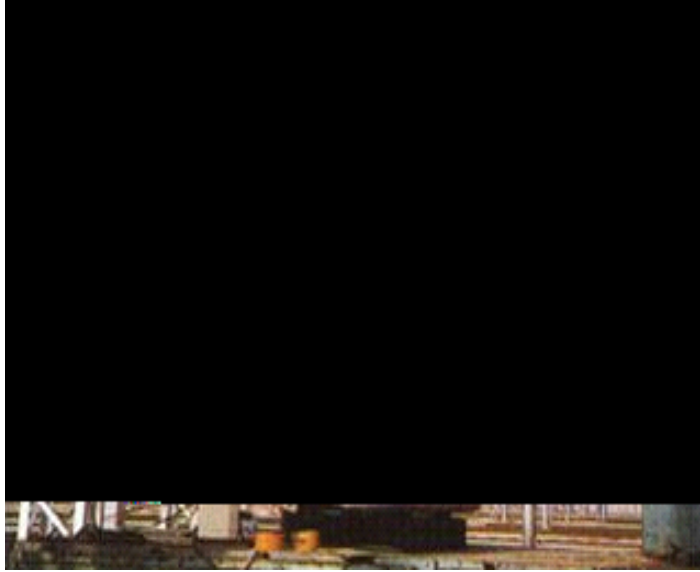

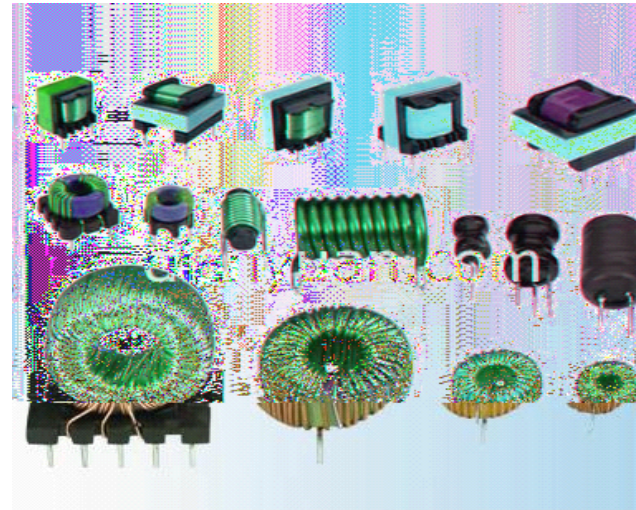
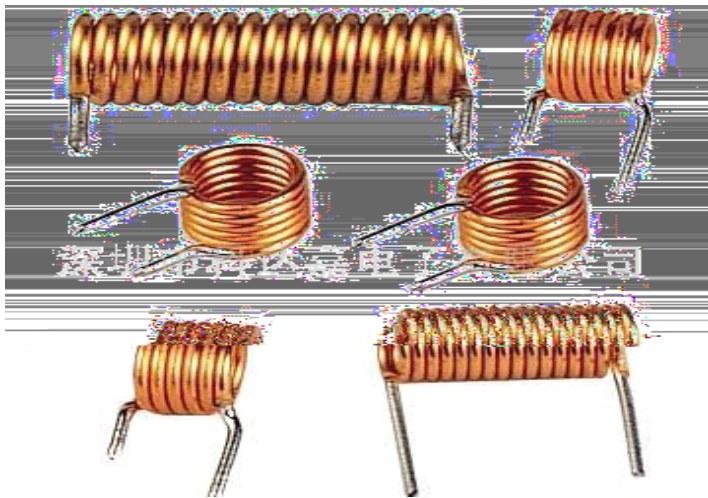
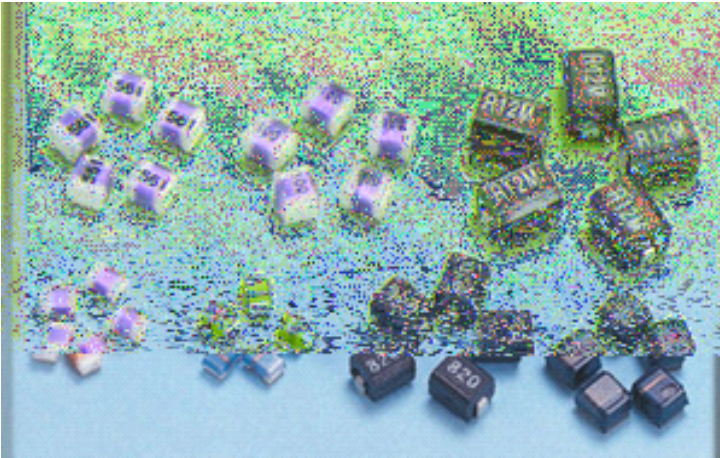



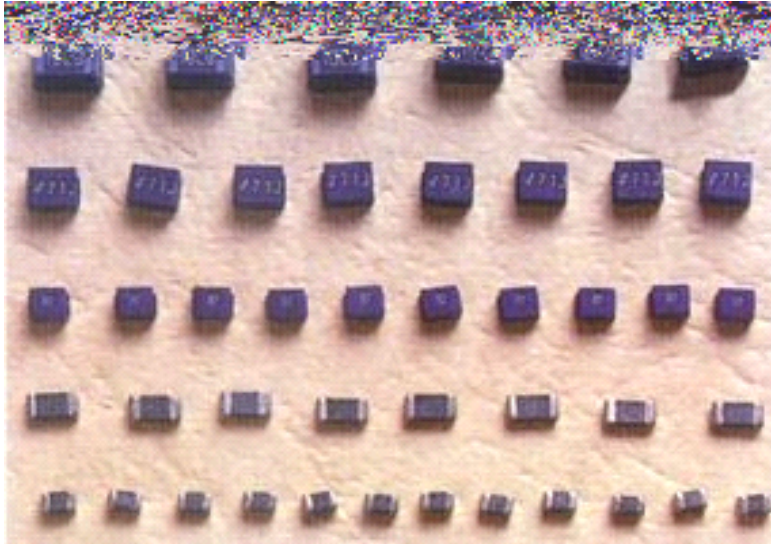

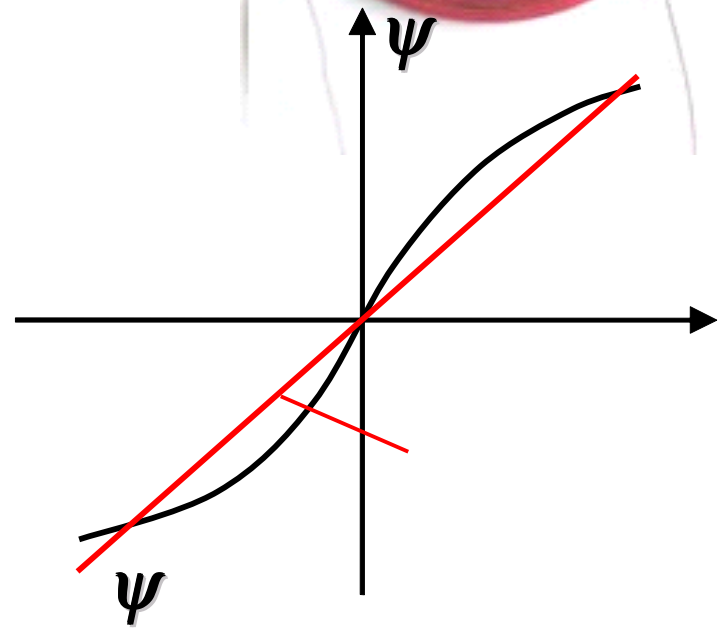

$\psi$

$\psi$

$\psi$

$\psi$

$\psi$

.



.

$\psi$

$\Psi$

$\mu$

$\mu$

.

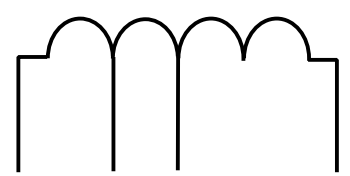
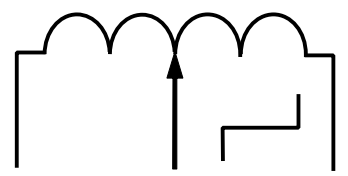
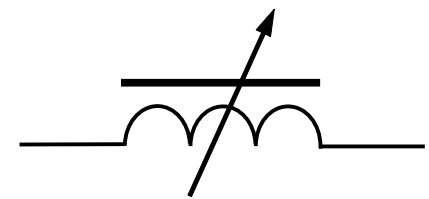



$\Psi$



$\Psi$



$$= -$$

$$\xi = -$$

$$\xi + -$$

$$\xi$$

$$= + - \xi$$

- ∞

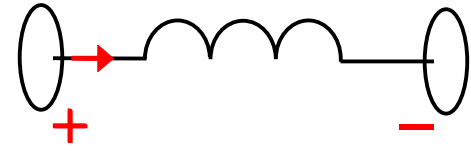

$$\Psi = \Psi + \xi = + - \xi$$

$$= - - = - - \xi$$



—



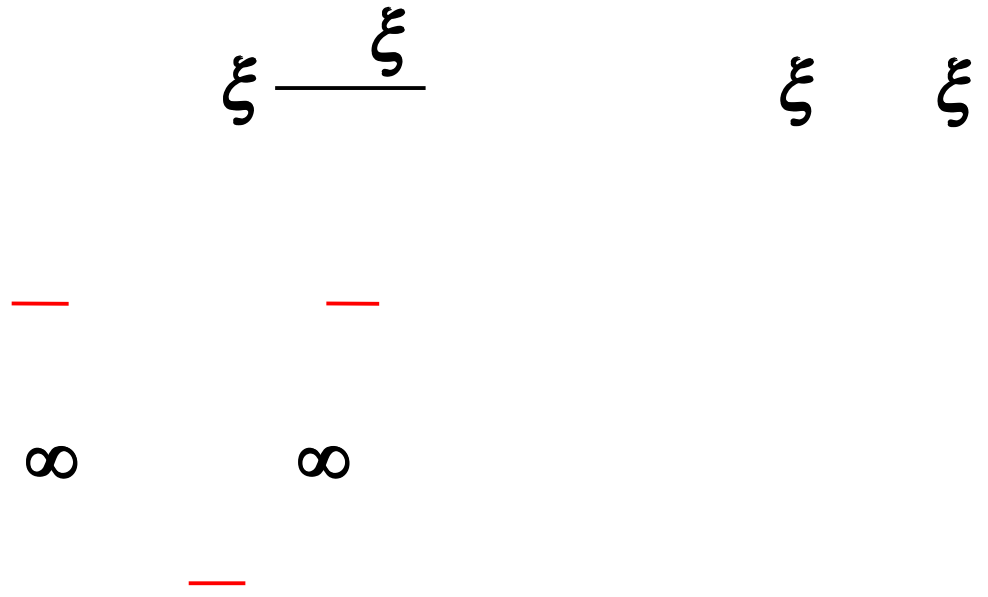



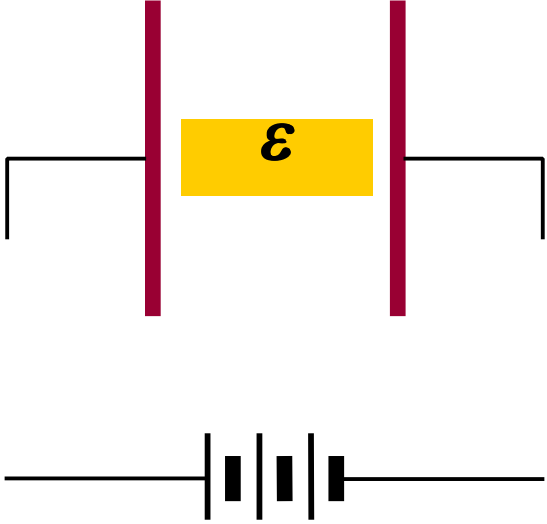

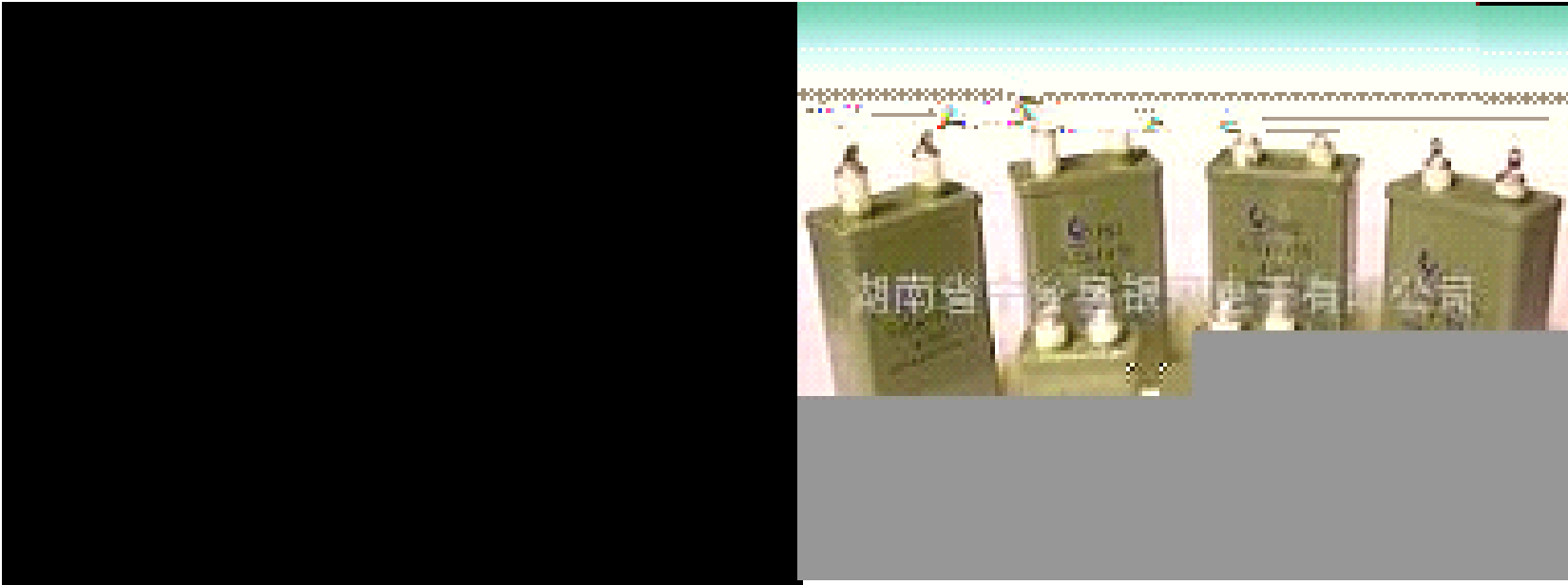

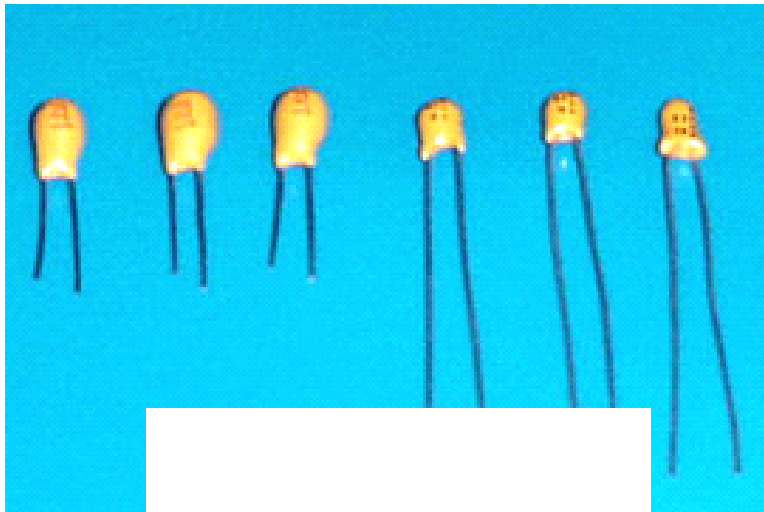
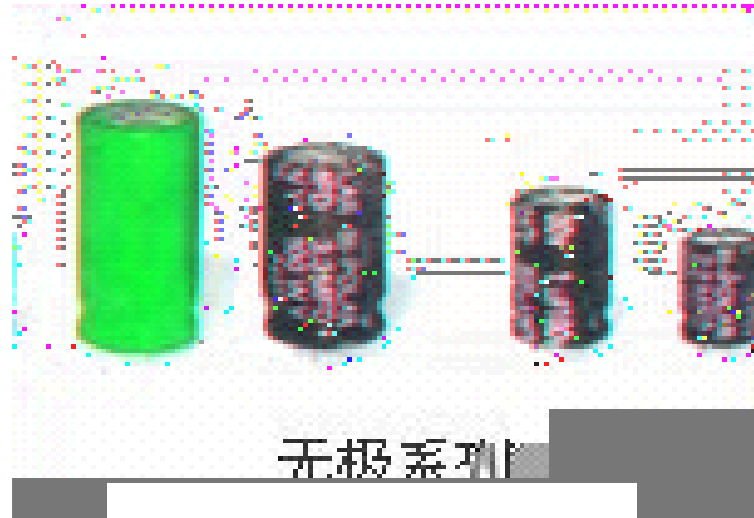

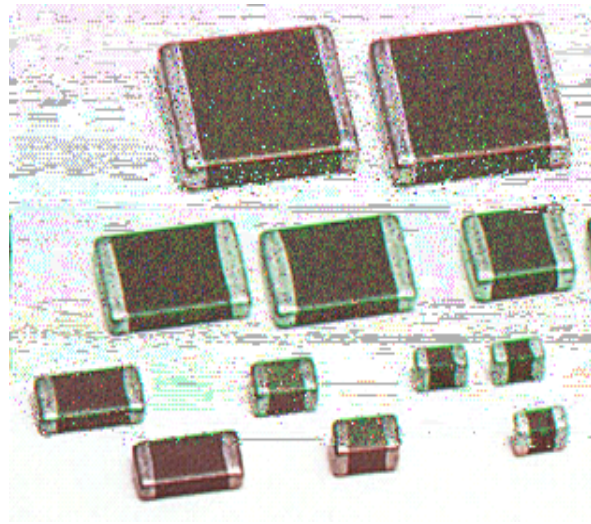
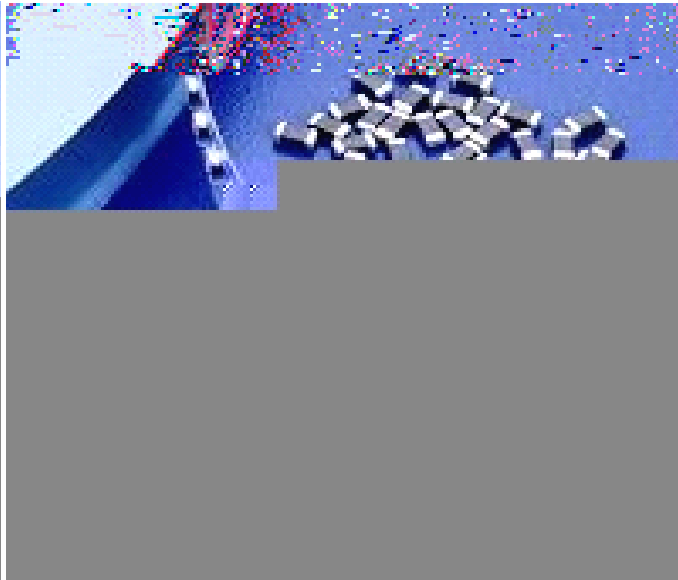
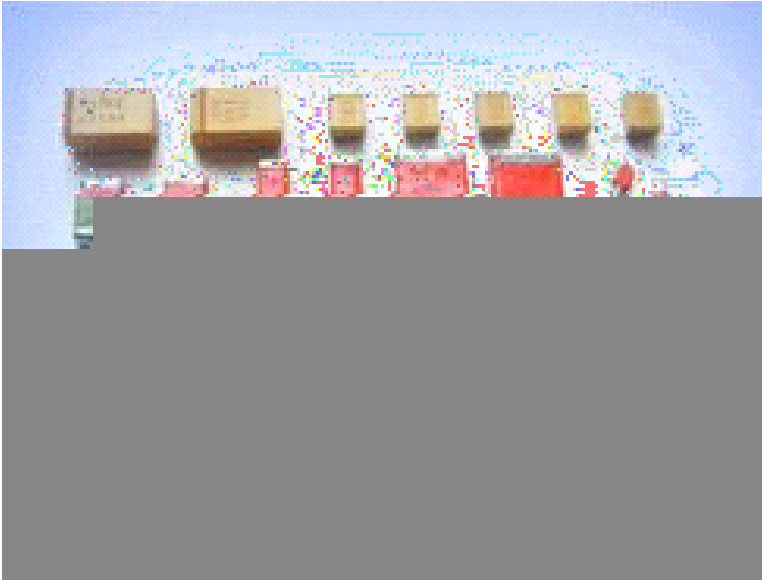

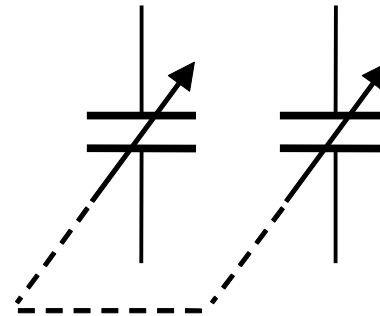
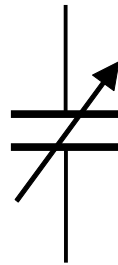
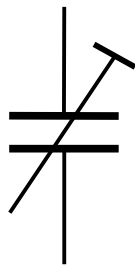
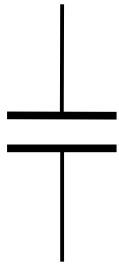

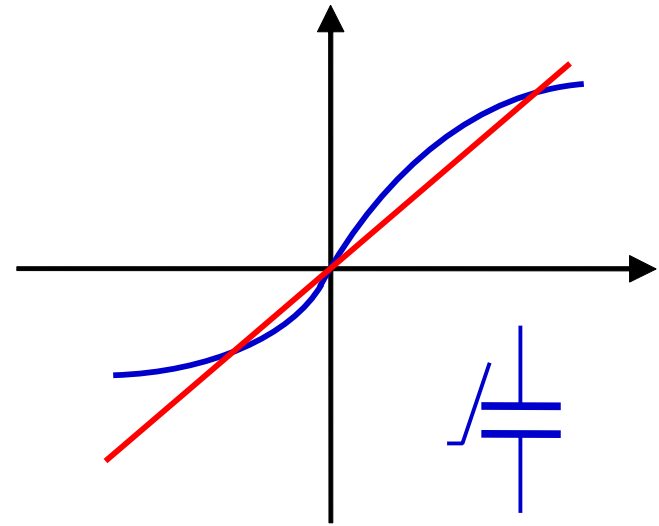

$\mu$





$$= |$$

$$= \xi \xi = \xi \xi + \xi \xi$$

-

-

$$= + \xi \xi$$

$$=$$

$$= + | \xi \xi$$

8





—

—

⌚

⌚



\_\_\_\_\_



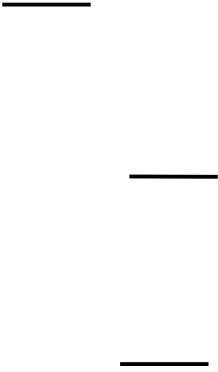

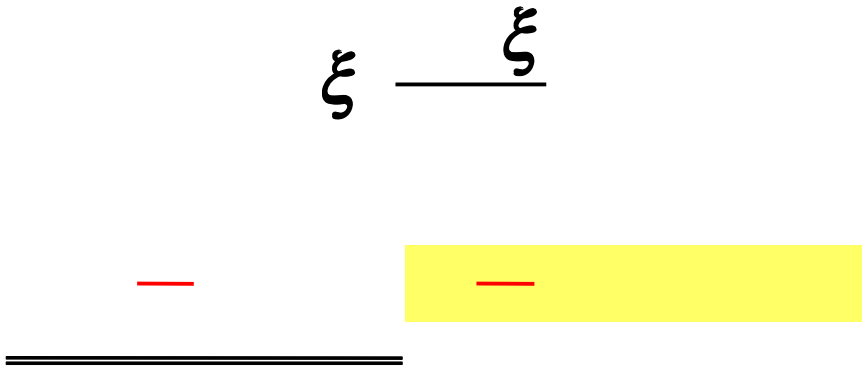

= -

0

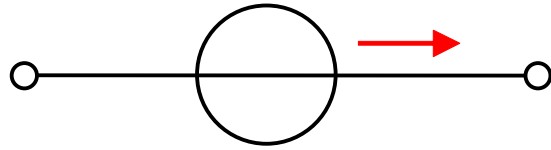

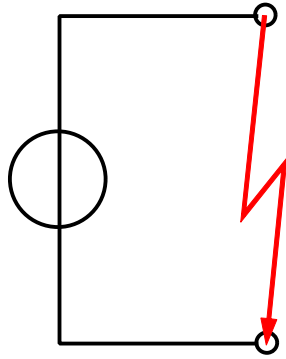
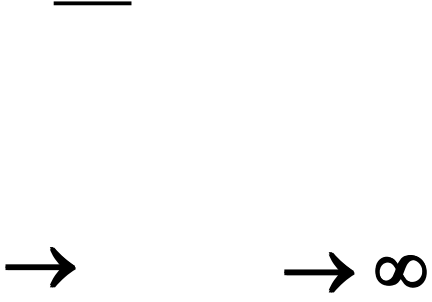
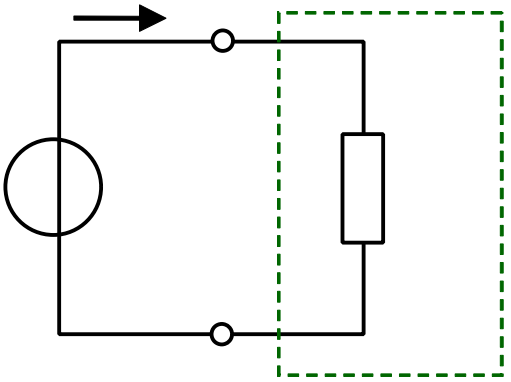
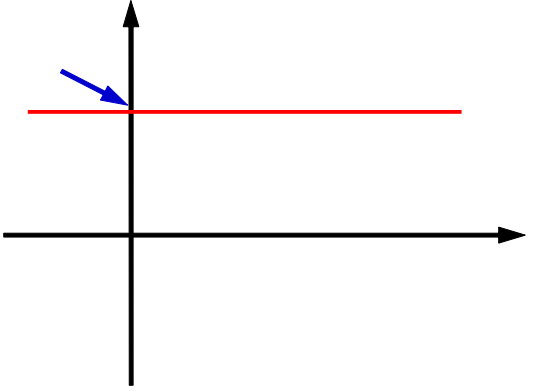

$\neq$



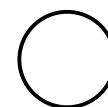
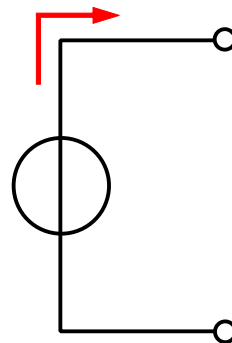

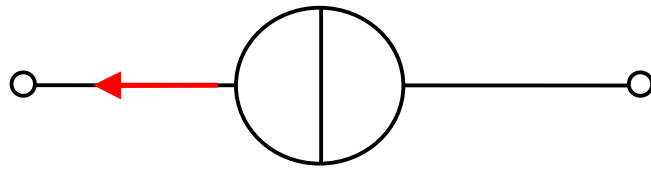

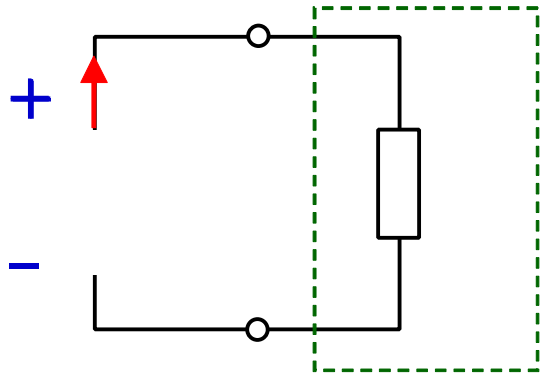
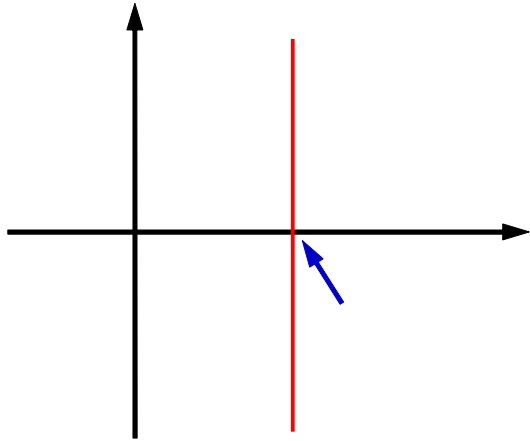

$$=$$

$$= 0( \quad ) =$$

$$\rightarrow \infty \quad \rightarrow \infty$$

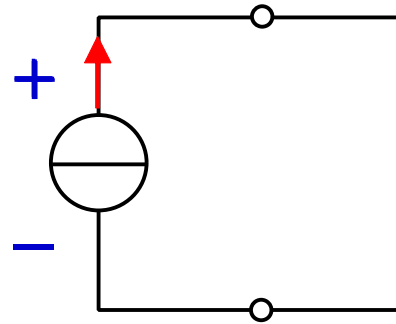

=





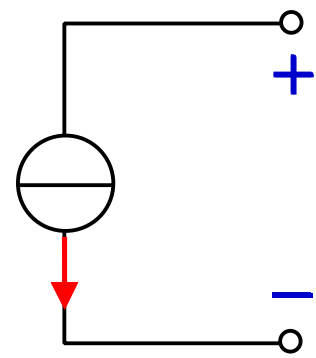
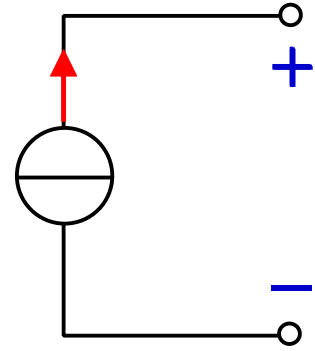

$$= \text{---} +$$

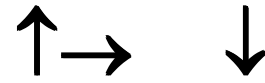
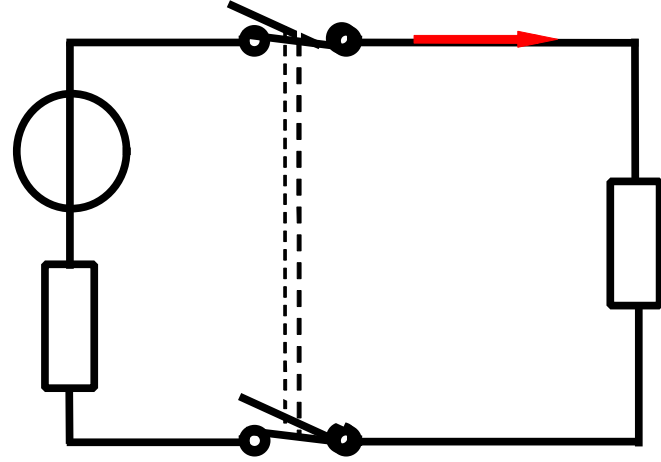
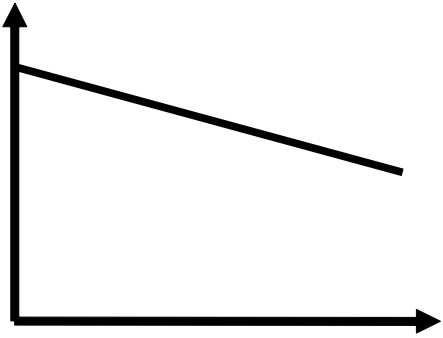

$$= \frac{\quad}{\quad} +$$

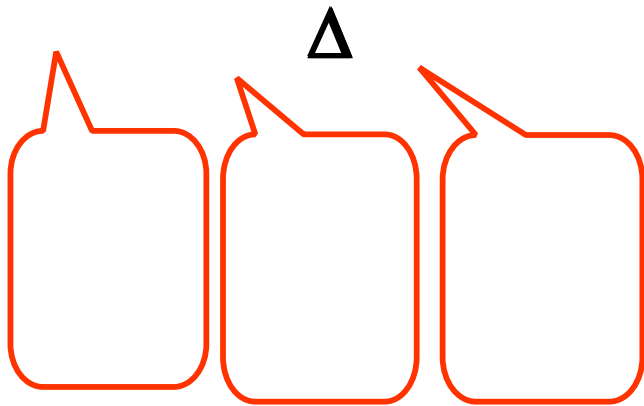
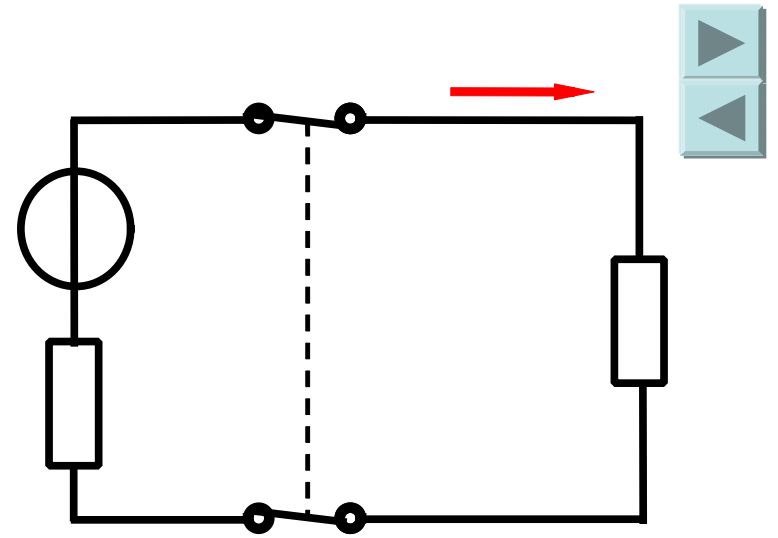



" + "

" - "

∨

∧

∨

∧



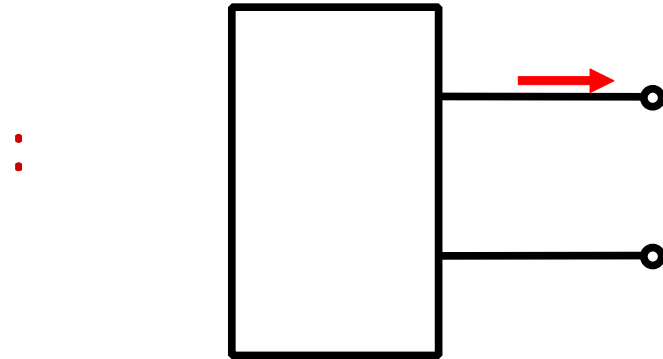
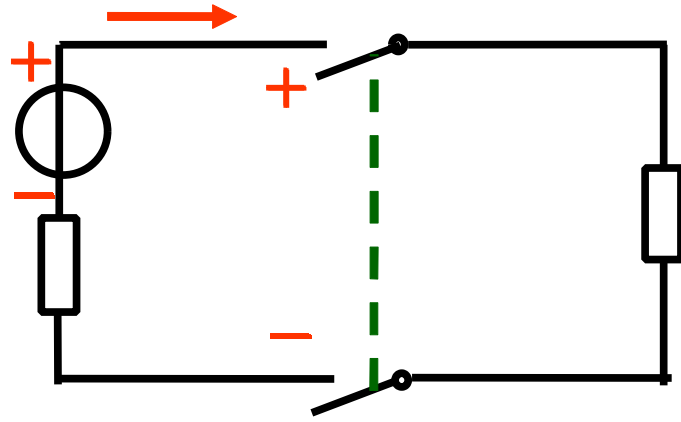

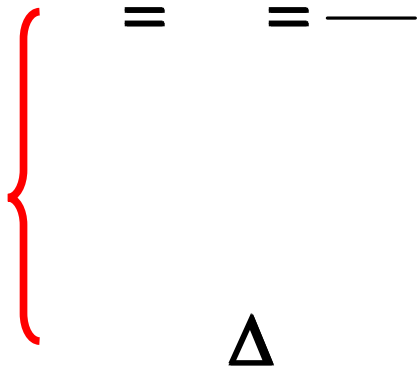

.

.

⋮

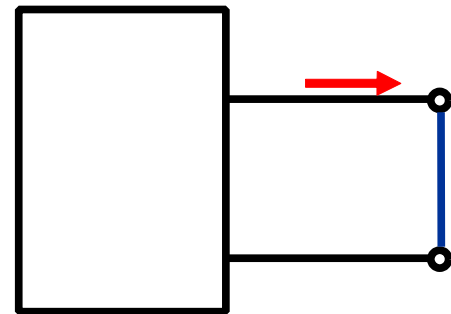
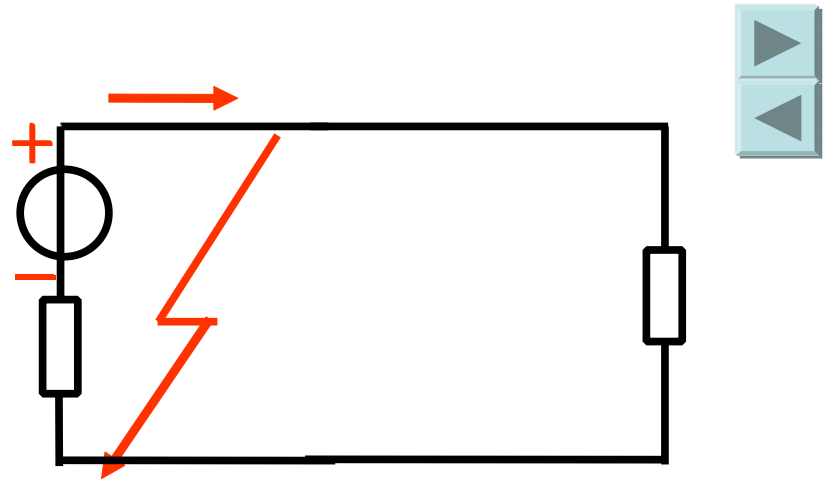

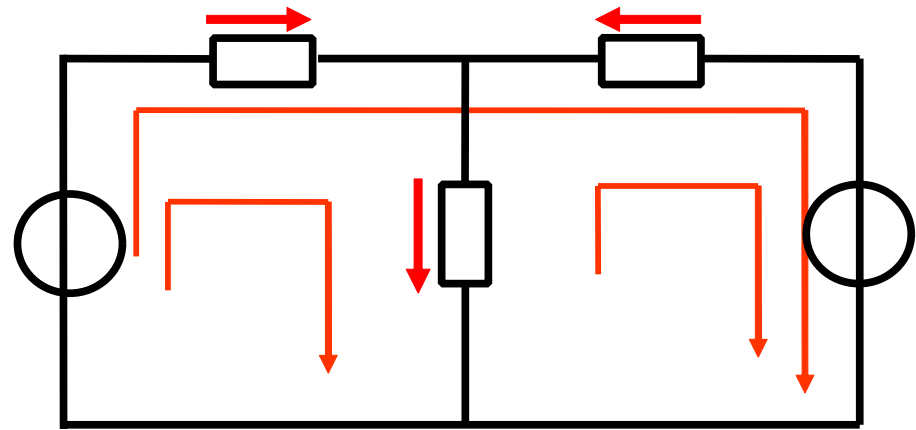



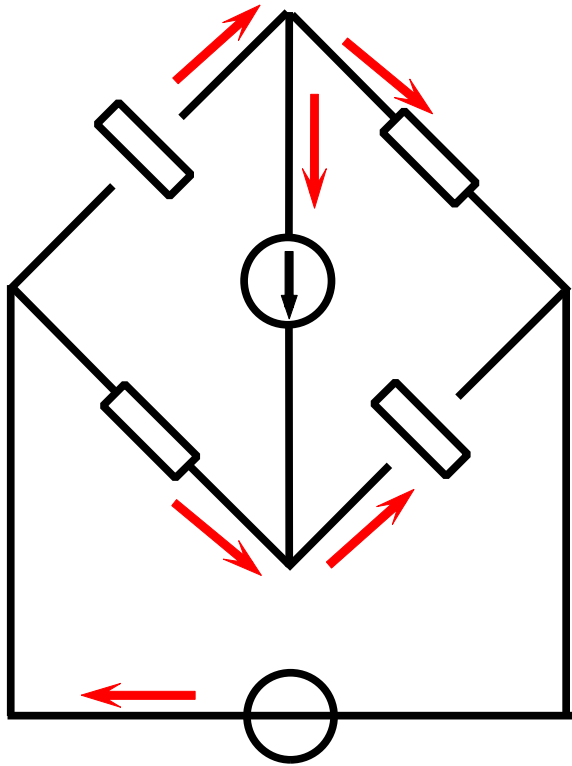

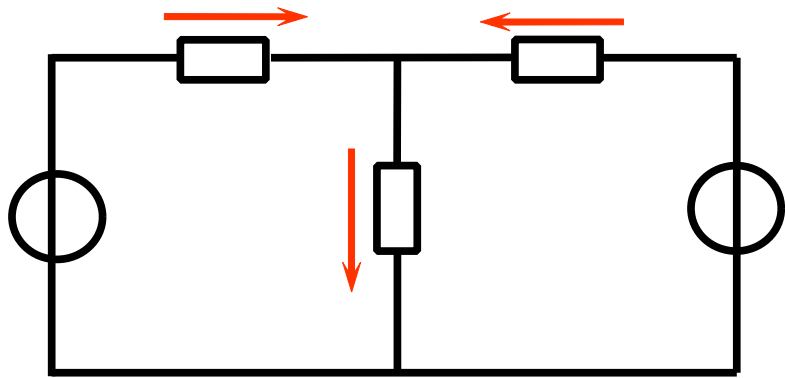

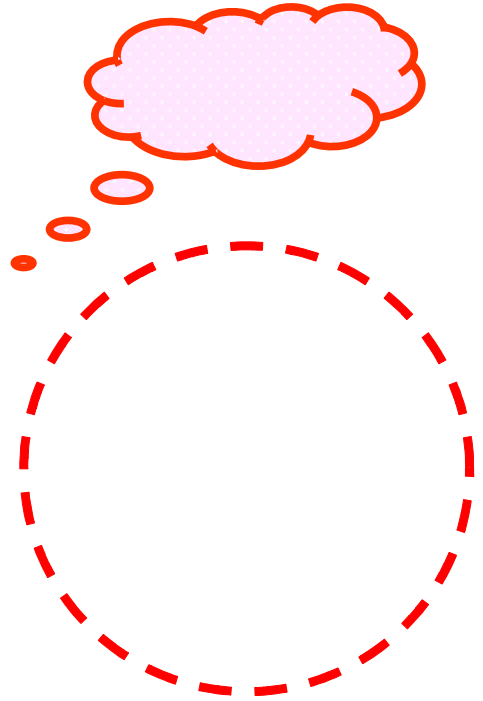

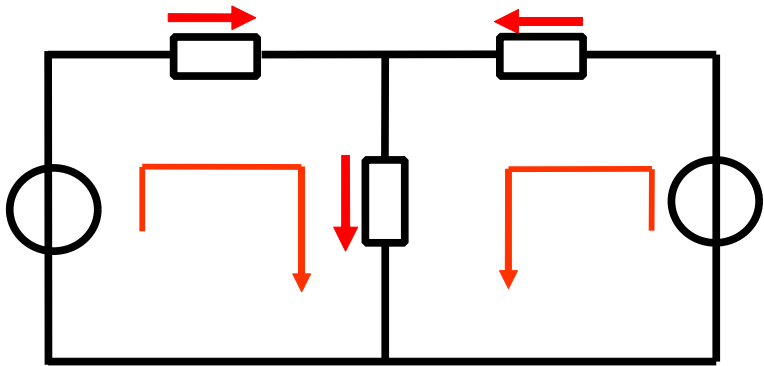

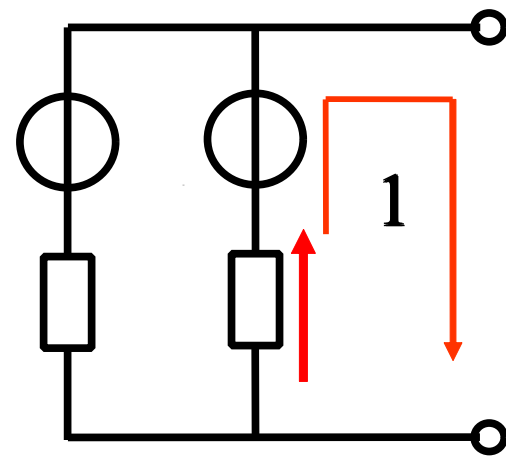
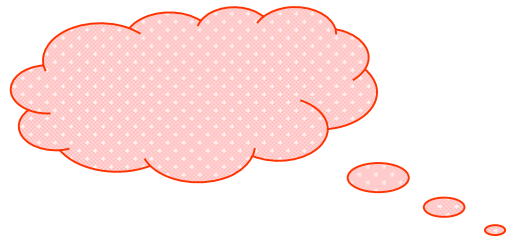





x  
x  
x

—

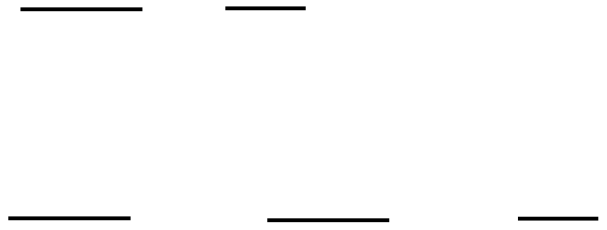
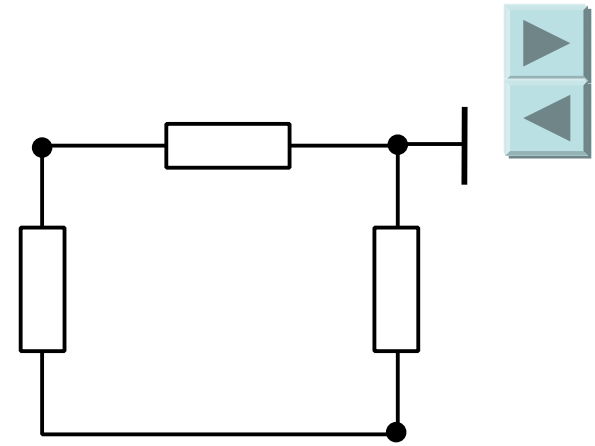



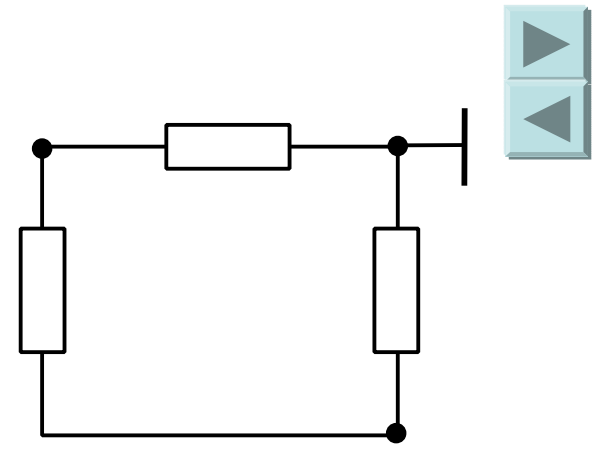

\_\_\_\_\_

\_\_\_\_\_

